

MMZ 8004 S

4-ZONE PRE AMPLIFIER

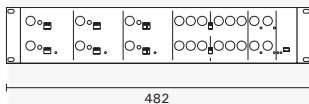

482

Pre Amplifier with 10 inputs and 4 outputs, fully mixing any input to any output

6 Microphone/line inputs
4 Aux/Music inputs (selectable for each output zone)
Microphone inputs have block switched Phantom Power (24V)

4 Separate output volume controls

Recording outputs
Connection points for 2 x **MBT 8004** 4 zone paging consoles

Automixer/gating facility on 3 x microphone inputs to overcome feedback in conference environments

19" Rack mounting, 2U high



4 ZONE PAGING - LOCAL PRIORITY

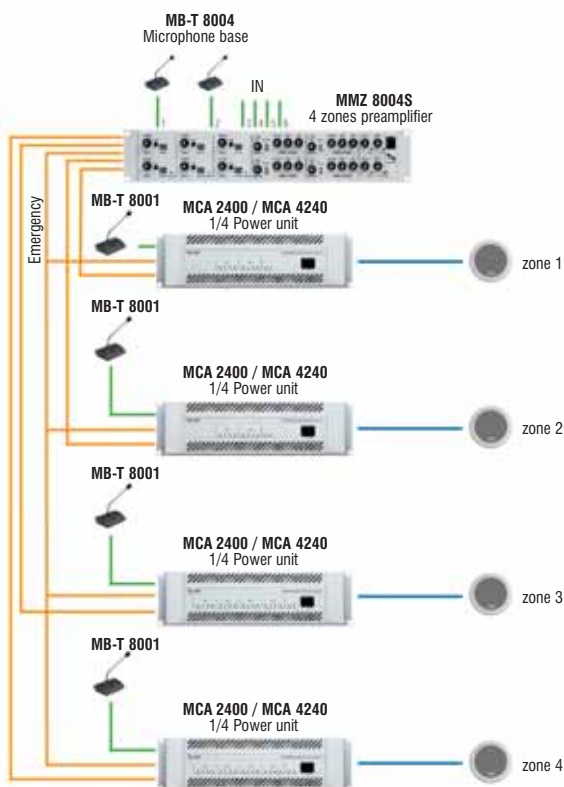

MMZ 8004 S

| | |
|--|--|
| Characteristics | 19" Rack mounting, 2U high with RAL 7035 grey paint finish |
| Microphone Max-gain line Input 1 and 2 | 6 mic/line inputs with Combo connector (XLR and JACK) 75dB/2 kohm Terminal board with option to select output 1,2,3 and 4 from a remote microphone |
| Max. gain line/Imp. | 4 stereo inputs pin jack RCA 40dB/33 kohm |
| Frequency response@0/-1dB | 20Hz~80KHz |
| S/N ratio@20db of gain | 110dB |
| Level control | 8 Volume controls, 6 GAIN controls, 2 Master |
| High pass filter | Channels 1~6 mic/line@80Hz-12dB/oct. |
| Voice control | 6 adjustment trimmers for voice presence on mic inputs |
| Tone control | 2 separate bass and treble tone controls on music inputs only |
| Phantom Power supply Output 1, 2, 3 and 4 | 24V DC activated on mic inputs only Selectors enable routing of each input to output 1, 2, 3, 4 |
| Music Inputs | 4 stereo inputs on double RCA for CD, Tape, Tuner and Aux selected on each output zone |
| Outputs dB/Impedance | 28 dBu/600 ohm balanced |
| Auxiliary outputs | Direct outputs channels 1~6 + recording socket output 1, 2, 3 and 4 0dBu/600 ohm |
| Priority on music Remote controls | Settings from selectors on front panel (ducking) Optional cards for remote volume for outputs 1, 2, 3 and 4 - Automatic level control according to background noise on output 1 |
| Emergency control | Input with photo coupler, Open Collector output |
| Insert bus 1 and 2 | 6.3mm stereo jack socket to connect auxiliary equipment |
| LED indicators | LED indicating saturation level (peak) on outputs 1, 2, 3, and 4 - Phantom on (48V DC mic) |
| VAC power supply | 230V AC or 120V AC with internal power supply unit |
| Optional accessories | MMZ-AR card for automatic level control according to background noise (output 1 only). MMZ-VRC card for remote volume control for pair of outputs 1/2 |
| Weight | 3.8kg |
| Dimensions | 482 x 88 x 215mm (2U rack) |